

HIGHLIGHTS OF PRESCRIBING INFORMATION

These highlights do not include all the information needed to use XYNTHA safely and effectively. See full prescribing information for XYNTHA.

XYNTHA [Antihemophilic Factor (Recombinant), Plasma/Albumin-Free] For Intravenous Use, Freeze-Dried Powder in Prefilled Dual-Chamber Syringe

Initial U.S. Approval: 2008

INDICATIONS AND USAGE

XYNTHA is an Antihemophilic (Recombinant) Factor indicated for:

- Control and prevention of bleeding episodes in patients with hemophilia A (1.1)
- Surgical prophylaxis in patients with hemophilia A (1.2)

DOSAGE AND ADMINISTRATION

For intravenous use after reconstitution only (2)

- The required dosage is determined using the following formula:
Required units = body weight (kg) x desired factor VIII rise (IU/dL or % of normal) x 0.5 (IU/kg per IU/dL)
- Frequency of intravenous injection of the reconstituted product is determined by the type of bleeding episode and the recommendation of the treating physician. (2.1, 2.2)

DOSAGE FORMS AND STRENGTHS

XYNTHA freeze-dried powder is available as: 250, 500, 1000, 2000, or 3000 IU in a single-use prefilled dual-chamber syringe. (3)

CONTRAINDICATIONS

None.

WARNINGS AND PRECAUTIONS

- Anaphylaxis and severe hypersensitivity reactions are possible. Should such reactions occur, treatment with the product should be discontinued, and appropriate treatment should be administered. (5.1)
- Development of activity-neutralizing antibodies has been detected in patients receiving factor VIII-containing products. If expected plasma factor VIII activity levels are not attained, or if bleeding is not controlled with an appropriate dose, an assay that measures factor VIII inhibitor concentration should be performed. (5.2, 5.4)
- Patients may develop hypersensitivity to hamster protein, which is present in trace amounts in the product. (5.3)

ADVERSE REACTIONS

The most common adverse reaction in Study 1 is headache (24% of subjects) and in Study 2 is pyrexia (41% of subjects). (6.1)

Two out of 89 subjects (who completed ≥ 50 exposure days) developed an inhibitor during the course of the study. The observation of 2 inhibitors in 89 subjects who completed ≥ 50 exposure days was consistent with a 95% probability that the inhibitor formation rate with XYNTHA is less than 4.17% using a Bayesian analysis. (6.1)

To report SUSPECTED ADVERSE REACTIONS, contact Wyeth Pharmaceuticals, Inc. at 1-800-934-5556 or FDA at 1-800-FDA-1088 or www.fda.gov/medwatch

DRUG INTERACTIONS

None.

USE IN SPECIFIC POPULATIONS

Pregnancy: No human or animal data. Use only if clearly needed. (8.1)

See 17 for PATIENT COUNSELING INFORMATION and FDA-approved patient labeling

Revised: 08/2010

FULL PRESCRIBING INFORMATION: CONTENTS*

1 INDICATIONS AND USAGE

- 1.1 Control and Prevention of Bleeding Episodes in Hemophilia A
- 1.2 Surgical Prophylaxis in Patients with Hemophilia A

2 DOSAGE AND ADMINISTRATION

- 2.1 Control and Prevention of Bleeding Episodes
- 2.2 Surgical Prophylaxis in Patients with Hemophilia A
- 2.3 Instructions for Use
- 2.4 Preparation and Reconstitution
- 2.5 Administration
- 2.6 Use of a XYNTHA Vial Kit and a XYNTHA Prefilled Dual-Chamber Syringe Kit
- 2.7 Multiple XYNTHA Prefilled Dual-Chamber Syringe Reconstitution to a 10 cc or Larger Luer Lock Syringe

3 DOSAGE FORMS AND STRENGTHS

4 CONTRAINDICATIONS

5 WARNINGS AND PRECAUTIONS

- 5.1 Anaphylaxis and Severe Hypersensitivity Reactions
- 5.2 Neutralizing Antibodies
- 5.3 Formation of Antibodies to Hamster Protein
- 5.4 Monitoring: Laboratory Tests

6 ADVERSE REACTIONS

- 6.1 Clinical Trials Experience

7 DRUG INTERACTIONS

8 USE IN SPECIFIC POPULATIONS

- 8.1 Pregnancy
- 8.2 Labor and Delivery
- 8.3 Nursing Mothers
- 8.4 Pediatric Use
- 8.5 Geriatric Use

11 DESCRIPTION

12 CLINICAL PHARMACOLOGY

- 12.1 Mechanism of Action
- 12.2 Pharmacodynamics
- 12.3 Pharmacokinetics

13 NONCLINICAL TOXICOLOGY

- 13.1 Carcinogenesis, Mutagenesis, Impairment of Fertility
- 13.2 Animal Toxicology and/or Pharmacology

14 CLINICAL STUDIES

15 REFERENCES

16 HOW SUPPLIED/STORAGE AND HANDLING

- 16.1 How Supplied
- 16.2 Storage and Handling

17 PATIENT COUNSELING INFORMATION

* Sections or subsections omitted from the full prescribing information are not listed

FULL PRESCRIBING INFORMATION

1 INDICATIONS AND USAGE

1.1 Control and Prevention of Bleeding Episodes in Hemophilia A

XYNTHA Antihemophilic Factor (Recombinant), Plasma/Albumin-Free is indicated for the control and prevention of bleeding episodes in patients with hemophilia A (congenital factor VIII deficiency or classic hemophilia).

XYNTHA does not contain von Willebrand factor, and therefore is not indicated in patients with von Willebrand's disease.

1.2 Surgical Prophylaxis in Patients with Hemophilia A

XYNTHA Antihemophilic Factor (Recombinant), Plasma/Albumin-Free is indicated for surgical prophylaxis in patients with hemophilia A.

2 DOSAGE AND ADMINISTRATION

For Intravenous Use After Reconstitution

Treatment with XYNTHA Antihemophilic Factor (Recombinant), Plasma/Albumin-Free should be initiated under the supervision of a physician experienced in the treatment of hemophilia A.

Dosage and duration of treatment depend on the severity of the factor VIII deficiency, the location and extent of bleeding, and the patient's clinical condition. Doses administered should be titrated to the patient's clinical response. In the presence of an inhibitor, higher doses may be required.¹

One International Unit (IU) of factor VIII activity corresponds approximately to the quantity of factor VIII in one milliliter of normal human plasma. The calculation of the required dosage of factor VIII is based upon the empirical finding that, on average, 1 IU of factor VIII per kg body weight raises the plasma factor VIII activity by approximately 2 IU/dL.² The required dosage is determined using the following formula:

Required units = body weight (kg) x desired factor VIII rise (IU/dL or % of normal) x 0.5 (IU/kg per IU/dL)

The labeled potency of XYNTHA is based on the European Pharmacopoeia chromogenic substrate assay, in which the Wyeth manufacturing standard has been calibrated using a one-stage clotting assay. This method of potency assignment is intended to harmonize XYNTHA with clinical monitoring using a one-stage clotting assay [*see Clinical Pharmacology (12.3)*].

2.1 Control and Prevention of Bleeding Episodes

In the case of the following bleeding events, consideration should be given to maintaining the factor VIII activity at or above the plasma levels (in % of normal or in IU/dL) outlined below for the indicated period.

The following chart can be used to guide dosing in bleeding episodes:

Type of Bleeding Episode	Factor VIII Level Required (IU/dL or % of normal)	Frequency of Doses / Duration of Therapy
Minor		
Early hemarthrosis, minor muscle or oral bleeds.	20–40	Repeat every 12-24 hours as necessary until resolved. At least 1 day, depending upon the severity of the bleeding episode.
Moderate		
Bleeding into muscles. Mild head trauma. Bleeding into the oral cavity.	30–60	Repeat infusion every 12-24 hours for 3-4 days or until adequate local hemostasis is achieved.
Major		
Gastrointestinal bleeding. Intracranial, intra-abdominal or intrathoracic bleeding. Fractures.	60–100	Repeat infusion every 8-24 hours until bleeding is resolved.

2.2 Surgical Prophylaxis in Patients with Hemophilia A

In the case of the following bleeding events, consideration should be given to maintaining the factor VIII activity at or above the plasma levels (in % of normal or in IU/dL) outlined below for the indicated period. Monitoring of replacement therapy by means of plasma factor VIII activity is recommended, particularly for surgical intervention.

The following chart can be used to guide dosing in surgery:

Type of Surgery	Factor VIII Level Required (IU/dL or % of normal)	Frequency of Doses / Duration of Therapy
Minor		
Minor operations, including tooth extraction.	30–60	Repeat infusion every 12-24 hours for 3-4 days or until adequate local hemostasis is achieved. For tooth extraction, a single infusion plus oral antifibrinolytic therapy within 1 hour may be sufficient.
Major		
Major operations.	60–100	Repeat infusion every 8-24 hours until threat is resolved, or in the case of surgery, until adequate local hemostasis and wound healing are achieved.

2.3 Instructions for Use

XYNTHA is administered by intravenous (IV) infusion after reconstitution of the freeze-dried powder with the diluent (0.9% Sodium Chloride). Both the XYNTHA powder and the diluent are supplied within the prefilled dual-chamber syringe.

Patients should follow the specific reconstitution and administration procedures provided by their physicians. For instructions, patients should follow the recommendations in the *FDA-Approved Patient Labeling (17)*. The procedures below are provided as general guidelines for the reconstitution and administration of XYNTHA.

Additional instructions are provided after *Administration 2.5* that detail the use of a XYNTHA Prefilled Dual-Chamber Syringe and a XYNTHA vial or multiple XYNTHA Prefilled Dual-Chamber Syringes [see *Use of a XYNTHA Vial Kit and a XYNTHA Prefilled Dual-Chamber Syringe Kit (2.6)*, and *Multiple XYNTHA Prefilled Dual-Chamber Syringe Reconstitution to a 10 cc or Larger Luer Lock Syringe (2.7)*].

Note: If the patient uses more than one vial and/or prefilled dual-chamber syringe of XYNTHA per infusion, each vial and/or syringe should be reconstituted according to the instructions for that respective product kit. A separate 10 cc or larger luer lock syringe (not included in this kit) may be used to draw back the reconstituted contents of each vial or syringe.

2.4 Preparation and Reconstitution

Preparation

1. Always wash your hands before performing the following procedures.
2. Use aseptic technique (clean and germ-free) during the reconstitution procedure.
3. Use all components for the reconstitution and administration of this product as soon as possible after opening their sterile containers to minimize unnecessary exposure to the atmosphere.

Reconstitution

1. Allow the prefilled dual-chamber syringe of freeze-dried XYNTHA to reach room temperature.
2. Remove the contents of the XYNTHA Prefilled Dual-Chamber Syringe Kit and place on a clean surface, making sure you have all the supplies you will need.
3. Grasp the plunger rod as shown in the following diagram. Avoid contact with the shaft of the plunger rod. Screw the plunger rod firmly into the opening in the finger rest of the XYNTHA Prefilled Dual-Chamber Syringe by pushing and turning firmly until resistance is felt (approximately 2 turns).

Note: Throughout the reconstitution process, it is important to keep the XYNTHA Prefilled Dual-Chamber Syringe upright to prevent possible leakage.

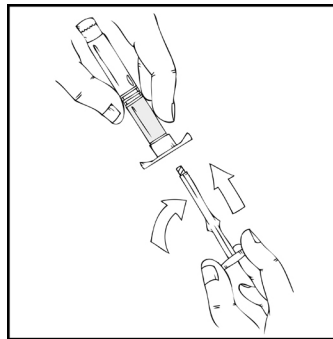

4. Holding the XYNTHA Prefilled Dual-Chamber Syringe upright, remove the white tamper-evident seal by bending the seal right to left (or a gentle rocking motion) to break the perforation of the cap and expose the grey rubber tip cap of the XYNTHA Prefilled Dual-Chamber Syringe.

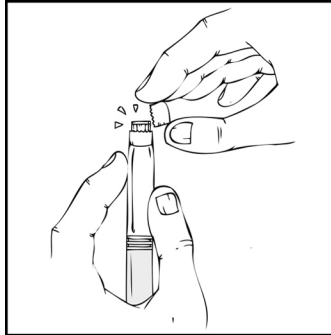

5. Remove the protective blue vented sterile cap from its package.

While holding the XYNTHA Prefilled Dual-Chamber Syringe upright, remove the grey rubber tip cap and replace it with the protective blue vented cap (prevents pressure build-up). Avoid touching the open end of both the syringe and the protective blue vented cap.

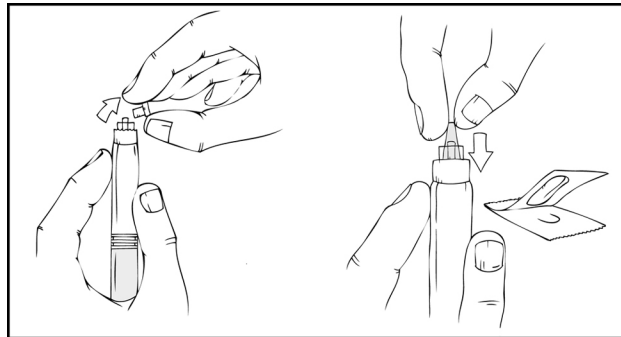

6. **Gently and slowly** advance the plunger rod by pushing until the two stoppers inside the XYNTHA Prefilled Dual-Chamber Syringe meet, and all of the diluent is transferred to the chamber containing the XYNTHA powder.

Note: To prevent the escape of fluid from the tip of the syringe, the plunger rod should not be pushed with excessive force.

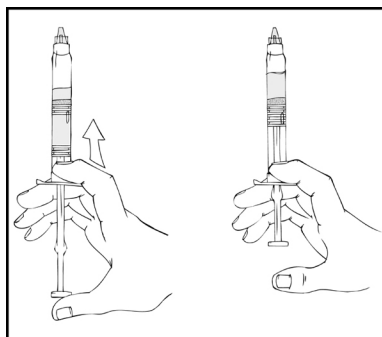

7. With the XYNTHA Prefilled Dual-Chamber Syringe remaining upright, swirl **gently** several times until the powder is dissolved.

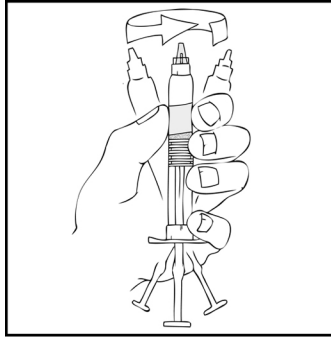

Note: The final solution should be inspected visually for particulate matter before administration. The solution should be clear to slightly opalescent and colorless. If it is not, the solution should be discarded and a new kit should be used.

8. Holding the XYNTHA Prefilled Dual-Chamber Syringe in an upright position, slowly advance the plunger rod until most, but not all, of the air is removed from the drug product chamber.

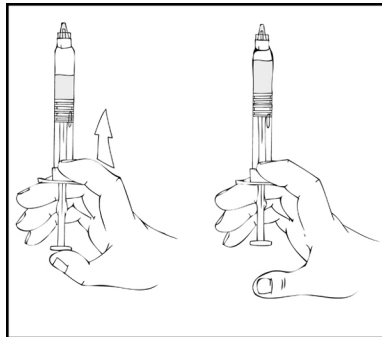

The reconstituted solution may be stored at room temperature prior to administration, but should be administered within 3 hours after reconstitution or removal of the grey rubber tip cap.

If the solution is not used immediately, the syringe should be stored upright and the protective blue vent cap should remain on the XYNTHA Prefilled Dual-Chamber Syringe until ready to infuse.

XYNTHA, when reconstituted, contains polysorbate 80, which is known to increase the rate of di-(2-ethylhexyl)phthalate (DEHP) extraction from polyvinyl chloride (PVC). This should be considered during the preparation and administration of XYNTHA, including storage time elapsed in a PVC container following reconstitution. It is important that the recommendations in *Dosage and Administration* (2) be followed closely.

Note: The tubing of the infusion set included with this kit does not contain DEHP.

2.5 Administration

XYNTHA is administered by intravenous (IV) infusion after reconstitution of the freeze-dried powder with the diluent (0.9% Sodium Chloride). Both the XYNTHA powder and the diluent are supplied within the prefilled dual-chamber syringe. Parenteral drug products should be inspected visually for particulate matter and discoloration prior to administration, whenever solution and container permit.

XYNTHA, as provided in the prefilled dual-chamber syringe, should routinely be administered using the infusion set included in the kit.

1. After removing the protective blue vented cap, firmly attach the intravenous infusion set provided in the kit onto the XYNTHA Prefilled Dual-Chamber Syringe.

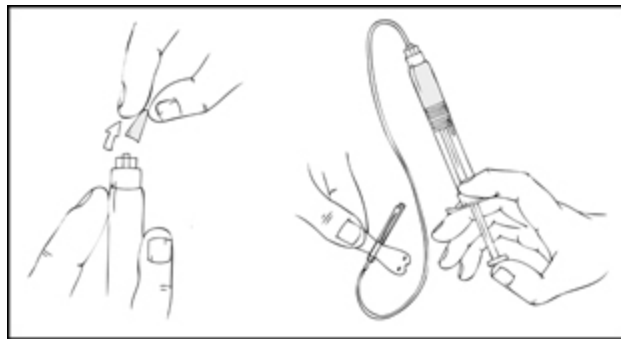

2. Apply a tourniquet and prepare the injection site by wiping the skin well with an alcohol swab provided in the kit.
3. Remove the protective needle cover and perform venipuncture. Insert the needle on the infusion set tubing into the vein, and remove the tourniquet. The reconstituted XYNTHA product should be injected intravenously over several minutes. The rate of administration should be determined by the patient's comfort level. As with any intravenous administration, always verify proper needle placement.

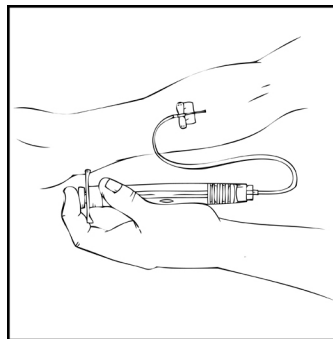

Reconstituted XYNTHA should not be administered in the same tubing or container with other medicinal products.³

4. After infusing XYNTHA, remove the infusion set and discard. The amount of drug product left in the infusion set will not affect treatment.

Note: Dispose of all unused solution, the empty XYNTHA Prefilled Dual-Chamber Syringe, and other used medical supplies in an appropriate container for medical waste that might hurt others if not handled properly.

2.6 Use of a XYNTHA Vial Kit and a XYNTHA Prefilled Dual-Chamber Syringe Kit

These instructions are for the use of only one XYNTHA vial kit and one XYNTHA Prefilled Dual-Chamber Syringe Kit. For further information, please contact the Medical Information Department at Wyeth Pharmaceuticals, 1-800-934-5556.

1. Reconstitute the XYNTHA vial using the instructions included with the kit. Detach the empty diluent syringe from the vial adapter by gently turning and pulling the syringe counterclockwise, leaving the contents in the vial and the vial adapter in place.

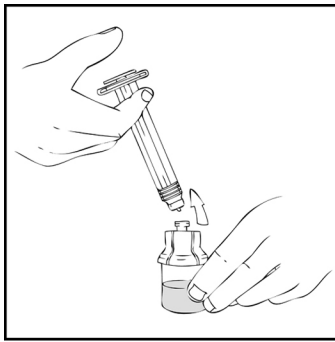

2. Reconstitute the XYNTHA Prefilled Dual-Chamber Syringe using the instructions included with the kit, remembering to remove most, but not all, of the air from the drug product chamber.

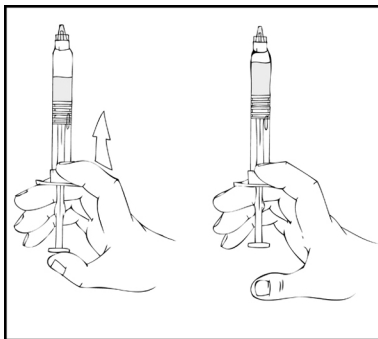

3. After removing the protective blue vented cap, connect the XYNTHA Prefilled Dual-Chamber Syringe to the vial adapter by inserting the tip into the adapter opening while firmly pushing and turning the syringe clockwise until secured.

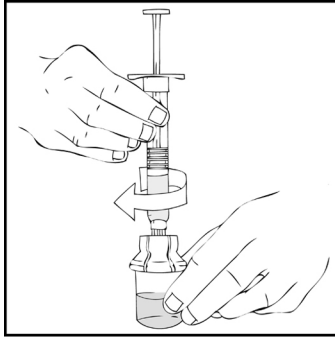

4. Slowly depress the plunger rod of the XYNTHA Prefilled Dual-Chamber Syringe until the contents empty into the XYNTHA vial. The plunger rod may move back slightly after release.

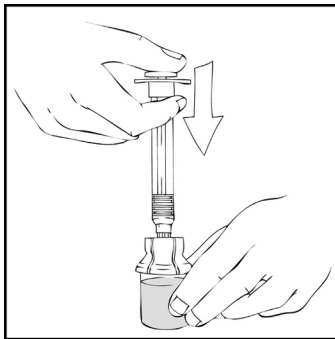

5. Detach and discard the empty XYNTHA Prefilled Dual-Chamber Syringe from the vial adapter.

Note: If the syringe turns without detaching from the vial adapter, grasp the white collar and turn.

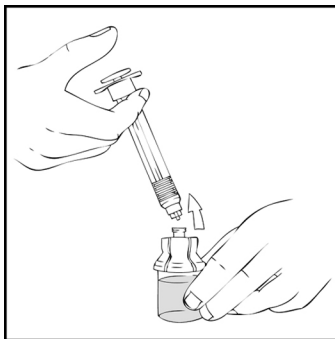

6. Connect a sterile 10 cc or larger luer lock syringe to the vial adapter. You may want to inject some air into the vial to make withdrawing the vial contents easier.

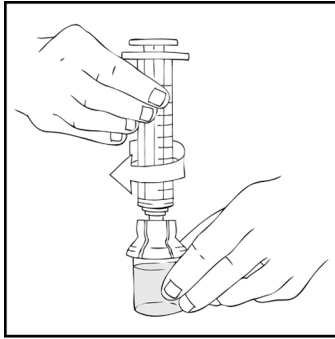

7. Invert the vial and slowly draw the solution into the 10 cc or larger luer lock syringe.

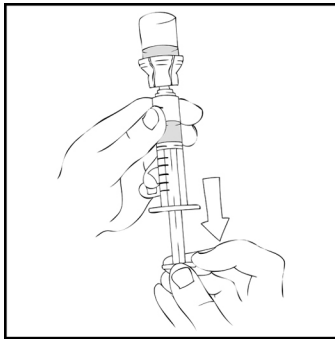

8. Detach the syringe from the vial adapter by gently turning and pulling the syringe counterclockwise. Discard the vial with the adapter attached.
9. Attach the infusion set to the 10 cc or larger luer lock syringe as directed [*see Dosage and Administration (2.5)*].

Note: Dispose of all unused solution, the empty XYNTHA Prefilled Dual-Chamber Syringe, and other used medical supplies in an appropriate container for medical waste that might hurt others if not handled properly.

2.7 Multiple XYNTHA Prefilled Dual-Chamber Syringe Reconstitution to a 10 cc or Larger Luer Lock Syringe

The instructions below are for the use of multiple XYNTHA Prefilled Dual-Chamber Syringe kits with a 10 cc or larger luer lock syringe. For further information, please contact the Medical Information Department at Wyeth Pharmaceuticals, 1-800-934-5556.

Note: Luer-to-luer syringe connectors are not provided in these kits. Instruct patients to contact their XYNTHA supplier to order.

1. Reconstitute all XYNTHA Prefilled Dual-Chamber Syringes according to instructions shown above [*see Dosage and Administration (2.4)*].

Holding the XYNTHA Prefilled Dual-Chamber Syringe in an upright position, slowly advance the plunger rod until most, but not all, of the air is removed from the drug product chamber.

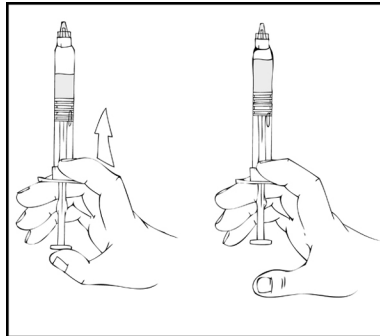

2. Remove the luer-to-luer syringe connector from its package.
3. After removing the protective blue vented cap, connect a sterile 10 cc or larger luer lock syringe to one opening (port) in the syringe connector and the XYNTHA Prefilled Dual-Chamber Syringe to the remaining open port on the opposite end.

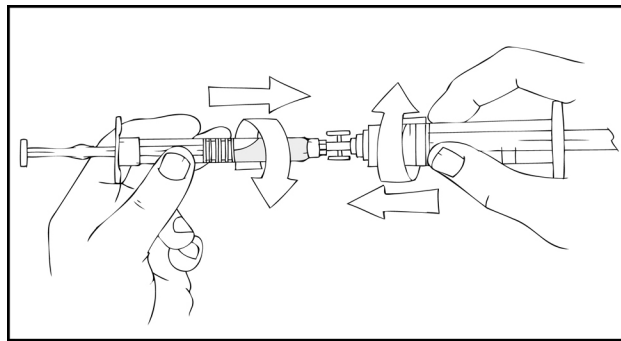

4. With the XYNTHA Prefilled Dual-Chamber Syringe on top, slowly depress the plunger rod until the contents empty into the 10 cc or larger luer lock syringe.

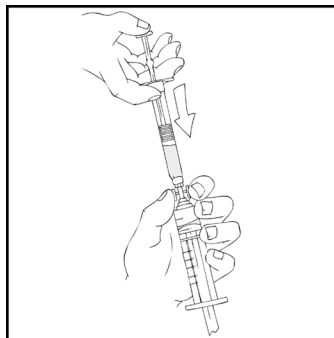

5. Remove the empty XYNTHA Prefilled Dual-Chamber Syringe and repeat procedures 3 and 4 above for any additional reconstituted syringes.

6. Remove the luer-to-luer syringe connector from the 10 cc or larger luer lock syringe and attach the infusion set as directed [*see Dosage and Administration (2.5)*].

Note: Dispose of all unused solution, the empty XYNTHA Prefilled Dual-Chamber Syringe(s), and other used medical supplies in an appropriate container for medical waste that might hurt others if not handled properly.

3 DOSAGE FORMS AND STRENGTHS

XYNTHA is supplied as a white to off-white freeze-dried powder in the following dosages:

- 250 IU
- 500 IU
- 1000 IU
- 2000 IU
- 3000 IU

4 CONTRAINDICATIONS

None.

5 WARNINGS AND PRECAUTIONS

5.1 Anaphylaxis and Severe Hypersensitivity Reactions

Allergic type hypersensitivity reactions are possible. Patients should be informed of the early signs or symptoms of hypersensitivity reactions [including hives (rash with itching), generalized urticaria, tightness of the chest, wheezing, and hypotension] and anaphylaxis [*see Patient Counseling Information (17)*].

Patients should be advised to discontinue use of the product and contact their physicians if these symptoms occur.

5.2 Neutralizing Antibodies

The occurrence of neutralizing antibodies (inhibitors) is well known in the treatment of patients with hemophilia A. Inhibitors have been detected in patients receiving factor VIII-containing products. Inhibitors are common in previously untreated patients^{4,5,6} and have been observed in previously treated patients on factor VIII products.^{7,8,9,10,11,12} Patients using coagulation factor VIII products, including XYNTHA, should be monitored for the development of factor VIII inhibitors. If expected factor VIII activity plasma levels are not attained, or if bleeding is not controlled with an appropriate dose, an assay should be performed to determine if a factor VIII inhibitor is present [*see Warnings and Precautions (5.4)*]. If detected, inhibitors should be titered in Bethesda Units (BU).

5.3 Formation of Antibodies to Hamster Protein

XYNTHA contains trace amounts of hamster proteins. Patients treated with this product could develop hypersensitivity to these non-human mammalian proteins.

5.4 Monitoring: Laboratory Tests

- Monitor plasma factor VIII activity levels by the one-stage clotting assay to confirm that adequate factor VIII levels have been achieved and are maintained, when clinically indicated [*see Dosage and Administration (2)*].
- It is recommended that individual factor VIII values for recovery and, if clinically indicated, other pharmacokinetic characteristics be used to guide dosing and administration.
- Monitor for development of factor VIII inhibitors. Perform assay to determine if factor VIII inhibitor is present when expected factor VIII activity plasma levels are not attained, or when bleeding is not controlled with the expected dose of XYNTHA. Use Bethesda Units (BU) to titer inhibitors.

6 ADVERSE REACTIONS

The most common adverse reaction in study 1 is headache (24% of subjects) and in study 2 is pyrexia (41% of subjects).

6.1 Clinical Trials Experience

Because clinical trials are conducted under widely varying conditions, adverse reaction rates observed in the clinical trials of a drug cannot be directly compared to rates in the clinical trials of another drug and may not reflect the rates observed in clinical practice.

Study 1 is a pivotal phase 3 (safety and efficacy) study in which previously treated patients (PTPs) with hemophilia A received XYNTHA for routine prophylaxis and on-demand treatment, 94 subjects received at least one dose of XYNTHA, resulting in a total of 6,775 infusions [*see Clinical Studies (14)*]. In Study 1, the most frequently reported treatment-emergent adverse reaction was headache (24% of subjects). Other adverse reactions reported in $\geq 5\%$ of subjects were: nausea (6%), diarrhea (5%), asthenia (5%) and pyrexia (5%). No subject developed anti-CHO or anti-TN8.2 antibodies.

Study 2 (surgery) is an on-going, open-label, single-arm study of at least 25 evaluable PTPs with severe or moderately severe hemophilia A (factor VIII activity in plasma [FVIII:C] $\leq 2\%$) who required elective major surgery and were planned to receive XYNTHA replacement therapy for at least 6 days post-surgery. Twenty-two subjects received at least one dose of XYNTHA, resulting in 766 infusions [*see Clinical Studies (14)*].

In Study 2, the most frequently reported treatment-emergent adverse reaction was pyrexia (41% of subjects). Other adverse reactions reported in $\geq 5\%$ of subjects were: headache (9%), nausea

(9%), diarrhea (5%), vomiting (5%) and asthenia (5%). The adverse reactions reported in either study were considered mild or moderate in severity.

Immunogenicity

In Study 1, the incidence of FVIII inhibitors to XYNTHA was the primary safety endpoint. Two subjects with inhibitors were observed in 89 subjects (2.2%) who completed ≥ 50 exposure days. These results were consistent with the pre-specified endpoint that no more than 2 inhibitors may be observed in at least 81 subjects.

In a Bayesian statistical analysis, results from this study were used to update PTP results from a prior supporting study using XYNTHA manufactured at the initial facility, where one *de novo* and two recurrent inhibitors were observed in 110 subjects, and the experience with predecessor product (1 inhibitor in 113 subjects). This Bayesian analysis indicates that the population (true) inhibitor rate for XYNTHA, the estimate of the 95% upper limit of the true inhibitor rate, was 4.17% (see Table 1).

Table 1: Bayesian Posterior Distribution of Inhibitor Rate

---Posterior Beta Distribution Characteristics---							
FVIII Inhibitor Nijmegen Result (BU/mL)	Number of Inhibitors	Number of Subjects Analyzed	Observed Inhibitor Rate (%)	Alpha ^a	Beta ^b	Posterior Probability ^c	95% Upper Limit of Inhibitor Rate (%) ^d
≥ 0.6	2	89	2.25	4.5	197	0.9613	4.17

^a Prior alpha of 2.5 plus the number of observed inhibitors.

^b Prior beta of 110 plus the number of subjects analyzed minus the number of observed inhibitors.

^c Posterior probability is the probability that the true inhibitor rate is less than the upper acceptable limit of 4.4%. A posterior probability greater than 0.95 is deemed acceptable.

^d The 95% upper limit of the true inhibitor rate (the maximum rate calculated with at least 95% probability) based on the posterior distribution. An inhibitor rate less than 4.4% is deemed acceptable.

7 DRUG INTERACTIONS

None known.

8 USE IN SPECIFIC POPULATIONS

8.1 Pregnancy

Pregnancy Category C

Animal reproduction studies have not been conducted with XYNTHA Antihemophilic Factor (Recombinant), Plasma/Albumin-Free. It is also not known whether XYNTHA can cause fetal

harm when administered to a pregnant woman or can affect reproduction capacity. XYNTHA should be given to a pregnant woman only if clinically indicated.

8.2 Labor and Delivery

There is no information available on the effect of factor VIII replacement therapy on labor and delivery. XYNTHA should be used only if clinically indicated.

8.3 Nursing Mothers

It is not known whether this drug is excreted into human milk. Because many drugs are excreted into human milk, caution should be exercised if XYNTHA is administered to nursing mothers. XYNTHA should be given to nursing mothers only if clinically indicated.

8.4 Pediatric Use

A study of XYNTHA in previously treated patients less than 6 years of age is currently ongoing.

Pharmacokinetics of XYNTHA was studied in 7 previously treated patients 12-16 years of age. Pharmacokinetic parameters in these patients were similar to those obtained for adults after a dose of 50 IU/kg. For these 7 patients, the mean (\pm SD) C_{\max} and AUC_{∞} were 1.09 ± 0.21 IU/mL and 11.5 ± 5.2 IU·h/mL, respectively. The mean clearance and plasma half-life values were 5.23 ± 2.36 mL/h/kg and 8.03 ± 2.44 hours (range 3.52 – 10.6 hours), respectively. The mean K-value and *in vivo* recoveries were 2.18 ± 0.41 IU/dL per IU/kg and $112 \pm 23\%$, respectively.

8.5 Geriatric Use

Clinical studies of XYNTHA did not include subjects aged 65 and over. In general, dose selection for an elderly patient should be individualized.

11 DESCRIPTION

Antihemophilic Factor (Recombinant), Plasma/Albumin-Free, the active ingredient in XYNTHA, is a recombinant coagulation factor VIII produced by recombinant DNA technology for use in therapy of factor VIII deficiency. The Antihemophilic Factor (Recombinant), Plasma/Albumin-Free in XYNTHA is a purified glycoprotein, with an approximate molecular mass of 170 kDa consisting of 1,438 amino acids, which does not contain the B-domain.¹³ The amino acid sequence of Antihemophilic Factor (Recombinant), Plasma/Albumin-Free in XYNTHA is comparable to the 90 + 80 kDa form of human factor VIII.

The Antihemophilic Factor (Recombinant), Plasma/Albumin-Free in XYNTHA is secreted by a genetically engineered Chinese hamster ovary (CHO) cell line. The cell line is grown in a chemically defined cell culture medium that contains recombinant insulin, but does not contain any materials derived from human or animal sources. The Antihemophilic Factor (Recombinant), Plasma/Albumin-Free in XYNTHA is purified by a process that uses a series of chromatography steps, one of which is based on affinity chromatography using a patented synthetic peptide affinity ligand.¹⁴ The process also includes a solvent-detergent viral inactivation step and a virus-retaining nanofiltration step.

The potency expressed in International Units (IU) is determined using the chromogenic assay of the European Pharmacopoeia. The Wyeth manufacturing reference standard for potency has been calibrated against the World Health Organization (WHO) International Standard for factor VIII activity using the one-stage clotting assay. The specific activity of XYNTHA is 5,500 to 9,900 IU per milligram of protein.

XYNTHA is formulated as a sterile, nonpyrogenic, preservative-free, freeze-dried powder preparation for intravenous (IV) injection. Each single-use prefilled dual-chamber syringe contains nominally 250, 500, 1000, 2000, or 3000 IU of XYNTHA. Upon reconstitution, the product is a clear to slightly opalescent, colorless solution that contains sodium chloride, sucrose, L-histidine, calcium chloride and polysorbate 80.

12 CLINICAL PHARMACOLOGY

12.1 Mechanism of Action

Factor VIII is the specific clotting factor deficient in patients with hemophilia A (classical hemophilia).¹⁵ Activated factor VIII acts as a cofactor for activated factor IX, accelerating the conversion of factor X to activated factor X.¹⁵ Activated factor X converts prothrombin into thrombin.¹⁵ Thrombin then converts fibrinogen into fibrin, and a clot is formed.¹⁵ Factor VIII activity is greatly reduced in patients with hemophilia A, and, therefore, replacement therapy is necessary. The administration of XYNTHA increases plasma levels of factor VIII activity and can temporarily correct the coagulation defect in these patients.

12.2 Pharmacodynamics

The administration of XYNTHA increases plasma levels of factor VIII activity and can temporarily correct the coagulation defect in hemophilia A patients.

12.3 Pharmacokinetics

In a pivotal crossover clinical study, 30 evaluable previously treated patients [PTP] (≥ 12 years) received a single infusion of 50 IU/kg of XYNTHA followed by a full-length recombinant FVIII (FLrFVIII, Advate[®]) or a single infusion of FLrFVIII followed by XYNTHA in a randomized crossover design. The one-stage clotting assay method was used to determine the concentrations of these two products in blood. XYNTHA was shown to be pharmacokinetically equivalent to FLrFVIII as the 90% confidence intervals for XYNTHA-to-FLrFVIII ratios of the mean values of C_{max} and AUC_{∞} were within pre-established limits of 80% to 125%. The pharmacokinetic parameters of XYNTHA in the above group of patients are summarized in [Table 2](#).

In addition, 25 PTPs received a single infusion of 50 IU/kg of XYNTHA for a 6-month follow-up PK study. The pharmacokinetic parameters were comparable between baseline and month 6, indicating no time-dependent changes in the pharmacokinetic properties of XYNTHA; the 90% confidence intervals for XYNTHA 6 month-to-baseline ratios of the mean values of C_{max} and AUC_{∞} were within pre-established limits of 80% to 125%.

Table 2: Pharmacokinetic Parameter Estimates for XYNTHA at Baseline (Cross-over phase) and Month 6 (Follow-up phase) in Previously Treated Patients with Hemophilia A

Parameter	Parameters at Initial Visit (Crossover phase, n = 30)	Parameters at Month 6 (Follow-up phase, n = 25)
	Mean ± SD	Mean ± SD
C _{max} (IU/mL)	1.08 ± 0.22	1.24 ± 0.42
AUC _∞ (IU·hr/mL)	13.5 ± 5.6	15.0 ± 7.5
t _{1/2} (hr)	11.2 ± 5.0	11.8 ± 6.2*
CL (mL/hr/kg)	4.51 ± 2.23	4.04 ± 1.87
K-value (IU/dL per IU/kg)	2.15 ± 0.44	2.47 ± 0.84
<i>In vivo</i> Recovery (%)	103 ± 21	116 ± 40

Abbreviations: AUC_∞ = area under the plasma concentration-time curve from zero to infinity; C_{max} = peak concentration; K-value = incremental recovery; t_{1/2} = plasma elimination half-life; CL = clearance; n = number of subjects; SD = standard deviation.

*One subject was excluded from the calculation due to lack of a well-defined terminal phase.

13 NONCLINICAL TOXICOLOGY

13.1 Carcinogenesis, Mutagenesis, Impairment of Fertility

No studies have been conducted with XYNTHA to assess its mutagenic or carcinogenic potential. XYNTHA has been shown to be comparable to the predecessor product with respect to its biochemical and physicochemical properties, as well as its non-clinical *in vivo* pharmacology and toxicology. By inference, predecessor product and XYNTHA would be expected to have equivalent mutagenic and carcinogenic potential. The predecessor product has been shown to be nongenotoxic in the mouse micronucleus assay. No studies have been conducted in animals to assess impairment of fertility or fetal development.

13.2 Animal Toxicology and/or Pharmacology

Preclinical studies evaluating XYNTHA in hemophilia A dogs without inhibitors demonstrated safe and effective restoration of hemostasis. XYNTHA demonstrated a toxicological profile that was similar to the toxicological profile observed with the predecessor product. Toxicity associated with XYNTHA was primarily associated with anti-FVIII neutralizing antibody generation first detectable at 15 days of repeat dosing in high (approximately 735 IU/kg/day) level-dosed, non-human primates.

14 CLINICAL STUDIES

The efficacy of XYNTHA was evaluated in Study 1, in which subjects received XYNTHA on a prophylaxis treatment regimen, with on-demand treatment administered as clinically indicated. Ninety-four (94) subjects were enrolled and treated with at least one dose, and all are included in the intent-to-treat (ITT) population. Eighty-nine (89) subjects accrued ≥ 50 exposure days. From the 94 subjects enrolled, thirty (30) evaluable subjects participated in the PK study and received at least 1 PK dose. Twenty-five (25) evaluable subjects with FVIII:C ≤ 1% completed both the

first (PK1) and the second (PK2) assessments [see *Clinical Pharmacology (12.3)*]. Median age for the 94 treated subjects was 24 years (mean 27.7 and range 12-60 years). All subjects had \geq 150 previous exposure days with baseline FVIII activity level of \leq 2%.

In the open-label safety and efficacy period, all 94 subjects received XYNTHA for routine prophylaxis at the dose of 30 ± 5 IU/kg 3 times a week with provisions for dose escalation based on pre-specified criteria. Seven (7) dose escalations were prescribed for 6 subjects during the course of the study. Forty-three (43) of ninety-four (94), i.e. 45.7%, subjects reported no bleeding while on routine prophylaxis. The median annualized bleeding rate (ABR) for all bleeding episodes was 1.9 (mean 3.9, range 0 to 42.1).

Fifty-three (53) of 94 subjects received XYNTHA for on-demand treatment for a total of 187 bleeding episodes (Table 3). Seven of these bleeding episodes occurred in subjects prior to switching to a prophylaxis treatment regimen. One hundred ten of one hundred eighty (110/180) bleeds (61.1%) occurred \leq 48 hours after the last dose and 38.9% (70 of 180 bleeds) occurred $>$ 48 hours after the last dose. The majority of bleeds reported to occur \leq 48 hours after the last prophylaxis dose were traumatic (64 of 110 bleeds; 58.2%). Forty-two (42) of 70 bleeds (60%) reported to occur $>$ 48 hours after the last prophylaxis dose were spontaneous. The on-demand treatment dosing regimen was determined by the investigator. The median dose for on-demand treatment was 30.6 IU/kg (range, 6.4 to 74.4 IU/kg).

Table 3: Time Interval Between Last Prophylaxis Dose of XYNTHA and Start of Bleed

≤ 24 hrs		$> 24 \leq 48$ hrs		$> 48 \leq 72$ hrs		> 72 hrs		Unknown ^a		Total Bleeding Episodes
Spon	Traum	Spon	Traum	Spon	Traum	Spon	Traum	Spon	Traum	
13	20	33	44	24	12	18	16	3	4	187

^a Bleeds with unknown start time or bleeds in which previous prophylaxis dose was before the start of the safety and efficacy period of the study. Abbreviations: Spon = spontaneous new bleed; Traum = new bleed due to trauma; hrs = hours.

The majority of bleeding episodes (173/187; 92.5%) resolved with 1 or 2 infusions. Subjects rated the outcomes of infusions on a pre-specified four (4) point hemostatic efficacy scale. One hundred thirty-two (132) of 187 bleeding episodes (70.6%) treated with XYNTHA were rated excellent or good in their response to initial treatment, 45 (24.1%) were rated moderate. Five [5] (2.7%) were rated no response, and 5 (2.7%) were not rated.

Table 4: Summary of Response to Infusions to Treat New Bleeding Episode by Number of Infusions Needed for Resolution

Response to 1st Infusion	-----Number of Infusions (%)-----					Total Number of Bleeds
	1	2	3	4	> 4	
Excellent	42 (95.5)	2 (4.5)	0 (0.0)	0 (0.0)	0 (0.0)	44
Good	69 (78.4)	16 (18.2)	3 (3.4)	0 (0.0)	0 (0.0)	88
Moderate	24 (53.3)	16 (35.6)	2 (4.4)	0 (0.0)	3 (6.7)	45
No Response	0 (0.0)	0 (0.0)	2 (40.0)	2 (40.0)	1 (20.0)	5
Not Assessed	4 (80.0)	0 (0.0)	0 (0.0)	1 (20.0)	0 (0.0)	5 ^a
Total	139 (74.3)	34 (18.2)	7 (3.7)	3 (1.6)	4 (2.1)	187

^a Includes 1 infusion with commercial FVIII that occurred before routine prophylaxis began.

In an on-going, open-label study of XYNTHA in surgical prophylaxis, 21 of at least 25 evaluable PTPs with severe or moderately severe (FVIII:C \leq 2%) hemophilia A undergoing major surgical procedures received XYNTHA. One (1) subject received XYNTHA for a pre-surgery pharmacokinetic assessment only and had not undergone surgery.

The results of an interim analysis on 21 of the 25 planned evaluable subjects who had undergone major surgical procedures (13 total knee replacements, 1 hip replacement, 3 synovectomies, 1 left ulnar nerve transposition release, 1 ventral hernia repair/scar revision, 1 knee arthroscopy, 1 revision and debridement of the knee after a total knee replacement) are presented in Table 5. For the 21 surgical subjects, investigator's ratings of efficacy at the end of surgery and at the end of the initial postoperative period were excellent or good for all assessments. All reported blood loss during the intra-operative and postoperative periods was rated normal with the exception of one subject who experienced iatrogenic bleeding.

Table 5: Summary of Hemostatic Efficacy

Time of Hemostatic Efficacy Assessment	Excellent	Good	Number of subjects
End of surgery	14 (67%)	7 (33%)	21
End of initial postoperative period ^a	16 (84%)	3 (16%)	19

^a Conclusion of initial postoperative period is date of discharge or postoperative Day 6, whichever occurs later.

15 REFERENCES

1. Nilsson IM, Berntorp EE and Freiburghaus C. Treatment of patients with factor VIII and IX inhibitors. *Thromb Haemost.* 1993;70(1):56-59.
2. Hoyer LW. Hemophilia A. *N Engl J Med.* 1994;330:38-47.
3. Juhlin F. Stability and Compatibility of Reconstituted Recombinant Factor VIII SQ, 250 IU/ml, in a System for Continuous Infusion. Pharmacia Document 9610224, 1996.
4. Ehrenforth S, Kreuz W, Scharrer I, et al. Incidence of development of factor VIII and factor IX inhibitors in hemophiliacs. *Lancet.* 1992;339:594-598.

5. Lusher J, Arkin S, Abildgaard CF, Schwartz RS, the Kogenate PUP Study Group. Recombinant factor VIII for the treatment of previously untreated patients with hemophilia A. *N Engl J Med.* 1993;328:453-459.
6. Bray GL, Gomperts ED, Courter S, et al. A multicenter study of recombinant factor VIII (Recombinate): safety, efficacy, and inhibitor risk in previously untreated patients with hemophilia A. *Blood.* 1994;83(9):2428-2435.
7. Kessler C, Sachse K. Factor VIII:C inhibitor associated with monoclonal-antibody purified FVIII concentrate. *Lancet.* 1990;335:1403.
8. Schwartz RS, Abildgaard CF, Aledort LM, et al. Human recombinant DNA-derived antihemophilic factor (factor VIII) in the treatment of hemophilia A. *N Engl J Med.* 1990;323:1800-1805.
9. White GC II, Courter S, Bray GL, et al. A multicenter study of recombinant factor VIII (Recombinate™) in previously treated patients with hemophilia A. *Thromb Haemost.* 1997;77(4):660-667.
10. Gruppo R, Chen H, Schroth P, et al. Safety and immunogenicity of recombinant factor VIII (Recombinate™) in previously untreated patients: A 7.3 year update. *Haemophilia.* 1998;4:228 (Abstract No. 291, XXIII Congress of the WFH, The Hague).
11. Scharrer I, Bray GL, Neutzling O. Incidence of inhibitors in haemophilia A patients - a review of recent studies of recombinant and plasma-derived factor VIII concentrates. *Haemophilia.* 1999;5:145-154.
12. Abshire TC, Brackmann HH, Scharrer I, et al. Sucrose formulated recombinant human antihemophilic Factor VIII is safe and efficacious for treatment of hemophilia A in home therapy: Results of a multicenter, international, clinical investigation. *Thromb Haemost.* 2000;83(6):811-816.
13. Sandberg H, Almstedt A, Brandt J, Castro VM, Gray E, Holmquist L, et al. Structural and Functional Characterization of B-Domain Deleted Recombinant Factor VIII. *Sem Hematol.* 2001;38 (Suppl. 4):4-12.
14. Kelley BD, Tannatt M, Magnusson R, Hagelberg S. Development and Validation of an Affinity Chromatography Step Using a Peptide Ligand for cGMP Production of Factor VIII. *Biotechnol Bioeng.* 2004;87(3):400-412.
15. Mann KG and Ziedens KB. Overview of Hemostasis. In: Lee CA, Berntorp EE and Hoots WK, eds. *Textbook of Hemophilia.* USA, Blackwell Publishing; 2005:1-4.

16 HOW SUPPLIED/STORAGE AND HANDLING

16.1 How Supplied

XYNTHA® Antihemophilic Factor (Recombinant), Plasma/Albumin-Free is supplied in a kit that includes the XYNTHA freeze-dried powder that contain nominally 250, 500, 1000, 2000, or 3000 IU and 4 mL 0.9 % Sodium Chloride solution for reconstitution in a prefilled dual-chamber syringe:

250 IU Kit: NDC 58394-022-03

500 IU Kit: NDC 58394-023-03

1000 IU Kit: NDC 58394-024-03

2000 IU Kit: NDC 58394-025-03

3000 IU Kit: NDC 58394-016-03

In addition, each XYNTHA Antihemophilic Factor (Recombinant), Plasma/Albumin-Free Kit contains: one plunger rod for assembly, one sterile infusion set, two alcohol swabs, one bandage, one gauze pad, one vented sterile cap, and one package insert.

XYNTHA[®] Antihemophilic Factor (Recombinant), Plasma/Albumin-Free is also supplied in kits that include single-use vials that contain nominally 250, 500, 1000, or 2000 IU of freeze-dried powder per vial:

250 IU Kit: NDC 58394-012-01

500 IU Kit: NDC 58394-013-01

1000 IU Kit: NDC 58394-014-01

2000 IU Kit: NDC 58394-015-01

Actual factor VIII activity in IU is stated on the label of each XYNTHA Antihemophilic Factor (Recombinant), Plasma/Albumin-Free prefilled dual-chamber syringe or vial.

16.2 Storage and Handling

Product as Packaged for Sale:

- Store XYNTHA under refrigeration at a temperature of 2° to 8°C (36° to 46°F) for up to 36 months from the date of manufacture until the expiration date stated on the label. XYNTHA may also be stored at room temperature not to exceed 25°C (77°F) for up to 3 months.
- The starting date at room temperature storage should be clearly recorded in the space provided on the outer carton. At the end of the 3-month period, the product must not be put back into the refrigerator, but must be used immediately or discarded.
- Do not use XYNTHA after the expiration date stated on the label or after 3 months when stored at room temperature, whichever is earlier.
- Do not freeze, to prevent damage to the XYNTHA Prefilled Dual-Chamber Syringe.
- During storage, avoid prolonged exposure of XYNTHA to light.

Product After Reconstitution:

- Administer XYNTHA within 3 hours after reconstitution or after removal of the grey rubber tip cap from the XYNTHA Prefilled Dual-Chamber Syringe. The reconstituted solution may be stored at room temperature prior to administration.

17 PATIENT COUNSELING INFORMATION

See Patient Product Information and [Instructions for Using XYNTHA](#).

Advise patients to report any adverse reactions or problems following XYNTHA administration to their physician or healthcare provider.

- Advise patients that allergic-type hypersensitivity reactions are possible and inform them of the early signs of hypersensitivity reactions [including hives (rash with itching), generalized urticaria, tightness of the chest, wheezing, hypotension] and anaphylaxis. Advise patients to discontinue use of the product and contact their physicians if these symptoms occur.
- Advise patients to contact their physician or treatment facility for further treatment and/or assessment, if they experience a lack of a clinical response to factor VIII replacement therapy, as this may be a manifestation of an inhibitor.
- Advise female patients to notify their physician if they become pregnant or intend to become pregnant during therapy.
- Advise nursing mothers to notify their physician if they are breastfeeding.
- Advise patients that local irritation may occur when infusing XYNTHA after the reconstitution in the prefilled dual-chamber syringe.
- Advise patients to consult with their healthcare professional prior to travel and to bring an adequate supply of XYNTHA, based on their current regimen, for anticipated treatment when traveling.

FDA-Approved Patient Labeling

Patient Product Information (PPI)

XYNTHA (ZIN-tha)

[ANTIHEMOPHILIC FACTOR (RECOMBINANT), PLASMA/ALBUMIN-FREE]

Please read this Patient Information carefully before using XYNTHA and each time you get a refill. There may be new information. This leaflet does not take the place of talking with your doctor about your medical problems or your treatment.

What is XYNTHA?

XYNTHA is an injectable medicine that is used to help control and prevent bleeding in people with hemophilia A. Hemophilia A is also called classic hemophilia.

XYNTHA is not used to treat von Willebrand's disease.

What should I tell my doctor before using XYNTHA?

Tell your doctor about all of your medical conditions, including if you:

- are pregnant or planning to become pregnant. It is not known if XYNTHA may harm your unborn baby.
- are breastfeeding. It is not known if XYNTHA passes into your milk and if it can harm your baby.

Tell your doctor and pharmacist about all of the medicines you take, including all prescription and non-prescription medicines, such as over-the-counter medicines, supplements, or herbal remedies.

How should I infuse XYNTHA?

See the **step-by-step instructions for infusing XYNTHA at the end of this leaflet**. You should always follow the specific instructions given by your doctor. The steps listed **below** are general guidelines for using XYNTHA. If you are unsure of the procedures, please call your doctor or pharmacist before using.

Call your doctor right away if bleeding is not controlled after using XYNTHA.

Your doctor will prescribe the dose that you should take.

Your doctor may need to take blood tests from time to time.

Talk to your doctor before traveling. You should plan to bring enough XYNTHA for your treatment during this time.

What if I take too much XYNTHA?

Call your doctor if you take too much XYNTHA.

What are the possible side effects of XYNTHA?

Allergic reactions may occur with XYNTHA. Call your doctor or get emergency treatment right away if you have any of the following symptoms:

- **wheezing**
- **difficulty breathing**
- **chest tightness**
- **turning blue (look at lips and gums)**
- **fast heartbeat**
- **swelling of the face**
- **faintness**
- **rash**
- **hives**

Your body can also make antibodies, called “inhibitors,” against XYNTHA, which may stop XYNTHA from working properly. Consult with your healthcare provider to make sure you are carefully monitored with blood tests for the development of inhibitors to factor VIII.

Some common side effects of XYNTHA are headache, fever, nausea, vomiting, diarrhea, or weakness. These are not all the possible side effects of XYNTHA.

Tell your doctor about any side effect that bothers you or that does not go away.

How should I store XYNTHA?

Do not freeze XYNTHA and protect from light.

Store the XYNTHA Prefilled Dual-Chamber Syringe in the refrigerator at 36° to 46°F (2° to 8°C). XYNTHA can last at room temperature (below 77°F) for up to 3 months. If you store XYNTHA at room temperature, be careful to write down the date you put XYNTHA at room temperature, so you will know when to throw it away. There is a space on the carton for you to write the date.

Throw away any unused XYNTHA after the expiration date.

Infuse XYNTHA within 3 hours after reconstitution or after removal of the grey rubber tip cap from the prefilled dual-chamber syringe. You may store the reconstituted solution at room temperature prior to infusion. If you have not used it in 3 hours, throw it away.

Do not use reconstituted XYNTHA if it is not clear to slightly opalescent and colorless.

Disposal of all XYNTHA materials, whether reconstituted or not, must be done using an appropriate medical waste container. Contact your healthcare professional if you need additional instructions.

What else should I know about XYNTHA?

Medicines are sometimes prescribed for purposes other than those listed here. Do not use XYNTHA for a condition for which it is not prescribed. Do not share XYNTHA with other people, even if they have the same symptoms that you have.

This leaflet summarizes the most important information about XYNTHA. If you would like more information, talk to your doctor. You can ask your doctor or pharmacist for information about XYNTHA that was written for healthcare professionals.

Instructions for Using XYNTHA

XYNTHA is supplied as a freeze-dried powder. Before it can be infused in your vein (intravenous injection), you must reconstitute the powder by mixing it with the 0.9% Sodium Chloride solution. Both the XYNTHA powder and the 0.9% Sodium Chloride solution are supplied in one prefilled dual-chamber syringe. XYNTHA should be reconstituted and infused

using the infusion set provided in this kit. Please follow the directions below for the proper use of this product.

Additional instructions for using XYNTHA are provided after **INFUSION (Intravenous Injection)** that detail the use of a XYNTHA Prefilled Dual-Chamber Syringe and a XYNTHA vial or multiple XYNTHA Prefilled Dual-Chamber Syringes.

PREPARATION AND RECONSTITUTION

Preparation

1. Always wash your hands before performing the following procedures.
2. Use aseptic technique (clean and germ-free) during the reconstitution procedure.
3. Use all components for the reconstitution and administration of this product as soon as possible after opening their sterile containers to minimize unnecessary exposure to the atmosphere.

Reconstitution

1. Allow the prefilled dual-chamber syringe of freeze-dried XYNTHA to reach room temperature.
2. Remove the contents of the XYNTHA Prefilled Dual-Chamber Syringe Kit and place on a clean surface, making sure you have all the supplies you will need.
3. Grasp the plunger rod as shown in the following diagram. Avoid contact with the shaft of the plunger rod. Screw the plunger rod firmly into the opening in the finger rest of the XYNTHA Prefilled Dual-Chamber Syringe by pushing and turning firmly until resistance is felt (approximately 2 turns).

Note: Throughout the reconstitution process, it is important to keep the XYNTHA Prefilled Dual-Chamber Syringe upright to prevent possible leakage.

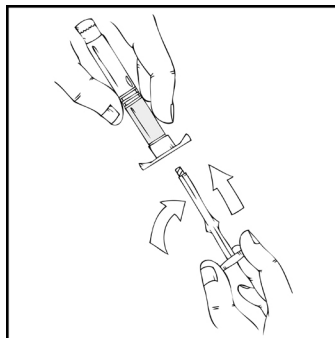

4. Holding the XYNTHA Prefilled Dual-Chamber Syringe upright, remove the white tamper-evident seal by bending the seal right to left (or a gentle rocking motion) to break

the perforation of the cap and expose the grey rubber tip cap of the XYNTHA Prefilled Dual-Chamber Syringe.

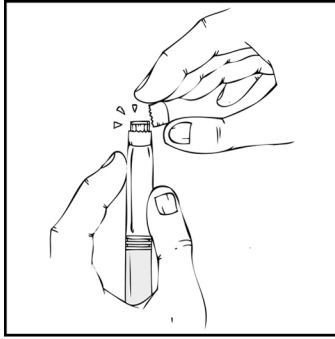

5. Remove the protective blue vented sterile cap from its package.

While holding the XYNTHA Prefilled Dual-Chamber Syringe upright, remove the grey rubber tip cap and replace it with the protective blue vented cap (prevents pressure build-up). Avoid touching the open end of both the syringe and the protective blue vented cap.

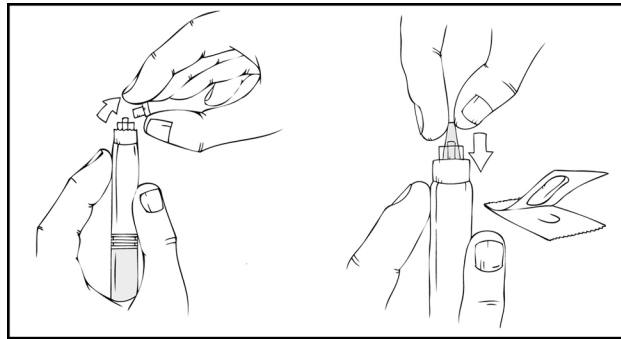

6. **Gently and slowly** advance the plunger rod by pushing until the two stoppers inside the XYNTHA Prefilled Dual-Chamber Syringe meet, and all of the diluent is transferred to the chamber containing the XYNTHA powder.

Note: To prevent the escape of fluid from the tip of the syringe, the plunger rod should not be pushed with excessive force.

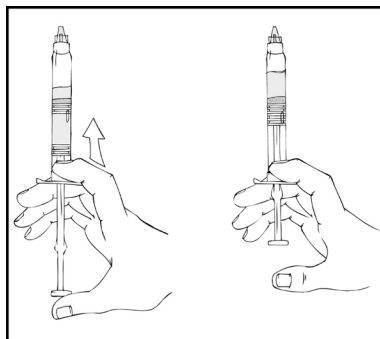

7. With the XYNTHA Prefilled Dual-Chamber Syringe remaining upright, swirl **gently** several times until the powder is dissolved.

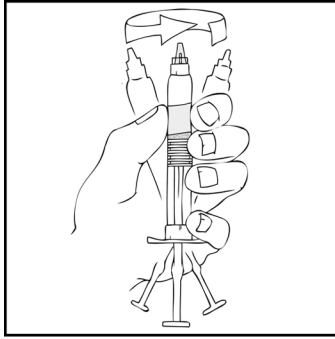

Note: Look carefully at the solution in the XYNTHA Prefilled Dual-Chamber Syringe. The solution should be clear to slightly opalescent and colorless. If it is not, the solution should be discarded and a new kit should be used.

8. Holding the XYNTHA Prefilled Dual-Chamber Syringe in an upright position, slowly advance the plunger rod until most, but not all, of the air is removed from the drug product chamber.

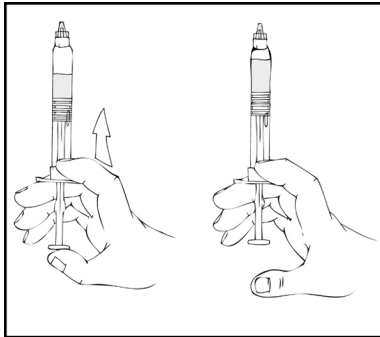

XYNTHA should be infused within 3 hours after reconstitution or removal of the grey tip cap from the prefilled dual-chamber syringe. The reconstituted solution may be stored at room temperature prior to infusion. If you have not used it in 3 hours, throw it away.

If the solution is not used immediately, the syringe should be stored upright and the protective blue vent cap should remain on the XYNTHA Prefilled Dual-Chamber Syringe until ready to infuse.

If more than one prefilled dual-chamber syringe of XYNTHA is needed for each infusion, a luer-to-luer syringe connector can be used (not included in this kit). Please contact your doctor or healthcare provider, or call the Wyeth Medical Information Department at 1-800-934-5556, for additional information.

INFUSION (Intravenous Injection)

Your doctor or healthcare professional should teach you how to infuse XYNTHA. Once you learn how to self-infuse, you can follow the instructions in this insert.

XYNTHA is administered by intravenous (IV) infusion after reconstitution of the freeze-dried powder with the diluent (0.9% Sodium Chloride). Both the XYNTHA powder and the diluent are supplied within the prefilled dual-chamber syringe. Once reconstituted, XYNTHA should be inspected visually for particulate matter and discoloration prior to administration.

XYNTHA, as provided in the prefilled dual-chamber syringe, should routinely be administered using the infusion set included in the kit.

1. After removing the protective blue vented cap, firmly attach the intravenous infusion set provided in the kit onto the XYNTHA Prefilled Dual-Chamber Syringe.

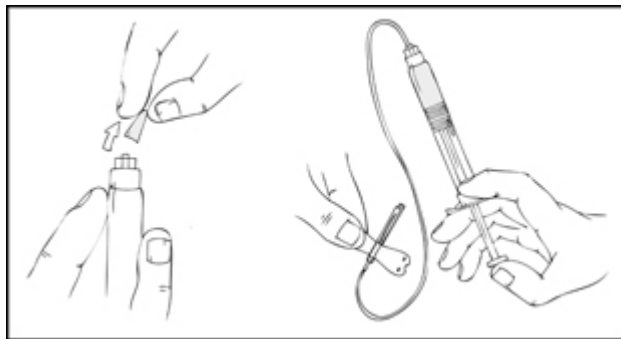

2. Apply a tourniquet and prepare the injection site by wiping the skin well with an alcohol swab provided in the kit.

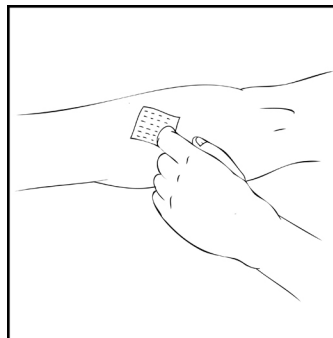

3. Remove the protective needle cover and insert the butterfly needle of the infusion set tubing into your vein as instructed by your doctor or healthcare professional. Remove the tourniquet. Infuse the reconstituted XYNTHA product over several minutes. Your comfort level should determine the rate of infusion.

As with any intravenous administration, always verify proper needle placement.

Discuss this procedure with your health care provider.

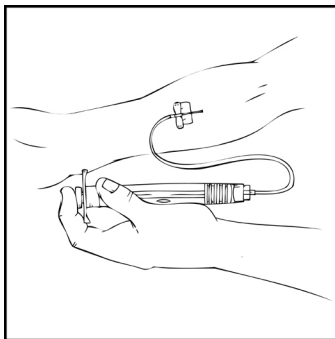

Reconstituted XYNTHA should not be administered in the same tubing or container with other medicinal products.

4. After infusing XYNTHA, remove the infusion set and discard. The amount of drug product left in the infusion set will not affect your treatment.

Note: Dispose of all unused solution, the empty XYNTHA Prefilled Dual-Chamber Syringe, and other used medical supplies in an appropriate container used for throwing away medical waste that might hurt others if not handled properly.

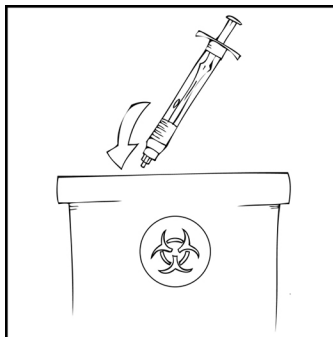

It is a good idea to record the lot number from the XYNTHA Prefilled Dual-Chamber Syringe label every time you use XYNTHA. You can use the peel-off label found on the XYNTHA Prefilled Dual-Chamber Syringe to record the lot number.

ADDITIONAL INSTRUCTIONS FOR USING XYNTHA

XYNTHA is also supplied in kits that include single-use vials with freeze-dried powder and prefilled diluent syringes.

If you use more than one vial and/or prefilled dual-chamber syringe of XYNTHA per infusion, each vial and/or syringe should be reconstituted according to the specific directions for that respective product kit. A separate, 10 cc or larger luer lock syringe (not included in this kit) may be used to draw back the reconstituted contents of each vial or syringe.

Use of a XYNTHA Vial Kit and a XYNTHA Prefilled Dual-Chamber Syringe Kit

These instructions are for the use of only one XYNTHA vial kit and one XYNTHA Prefilled Dual-Chamber Syringe Kit. For further information, please contact your healthcare provider or call the Medical Information Department at Wyeth Pharmaceuticals, 1-800-934-5556.

1. Reconstitute the XYNTHA vial using the instructions included with the kit. Detach the empty diluent syringe from the vial adapter by gently turning and pulling the syringe counterclockwise, leaving the contents in the vial and the vial adapter in place.



2. Reconstitute the XYNTHA Prefilled Dual-Chamber Syringe using the instructions included with the kit, remembering to remove most, but not all, of the air from the drug product chamber.

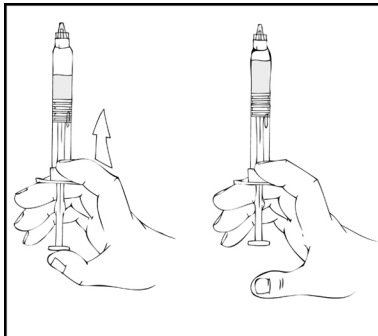

3. After removing the protective blue vented cap, connect the XYNTHA Prefilled Dual-Chamber Syringe to the vial adapter by inserting the tip into the adapter opening while firmly pushing and turning the syringe clockwise until secured.

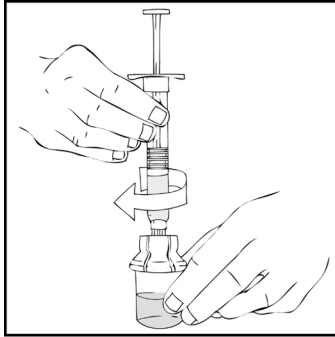

4. Slowly depress the plunger rod of the XYNTHA Prefilled Dual-Chamber Syringe until the contents empty into the XYNTHA vial. The plunger rod may move back slightly after release.

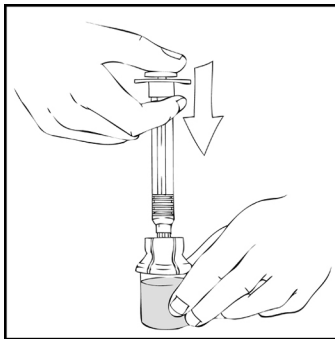

5. Detach and discard the empty XYNTHA Prefilled Dual-Chamber Syringe from the vial adapter.

Note: If the syringe turns without detaching from the vial adapter, grasp the white collar and turn.

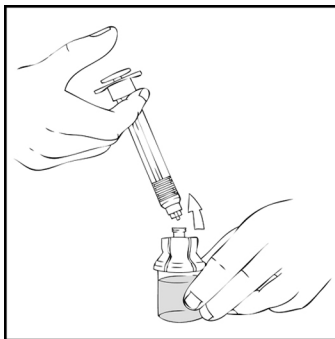

6. Connect a sterile 10 cc or larger luer lock syringe to the vial adapter. You may want to inject some air into the vial to make withdrawing the vial contents easier.

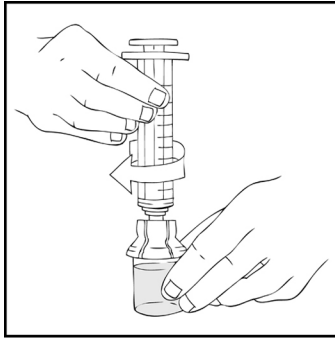

7. Invert the vial and slowly draw the solution into the 10 cc or larger luer lock syringe.

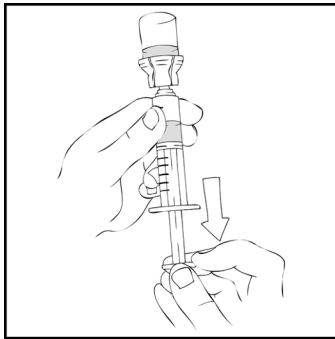

8. Detach the syringe from the vial adapter by gently turning and pulling the syringe counterclockwise. Discard the vial with the adapter attached.
9. Attach the infusion set to the 10 cc or larger luer lock syringe as directed [*see Dosage and Administration (2.5)*].

Note: Dispose of all unused solution, the empty XYNTHA Prefilled Dual-Chamber Syringe, and other used medical supplies in an appropriate container for throwing away medical waste that might hurt others if not handled properly.

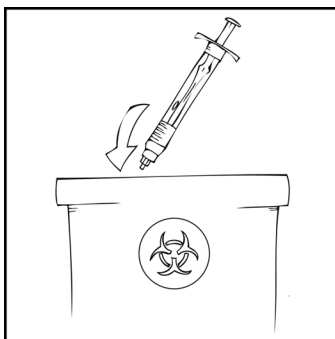

Multiple XYNTHA Prefilled Dual-Chamber Syringe Reconstitution to a 10 cc or Larger Luer Lock Syringe

The instructions below are for the use of multiple XYNTHA Prefilled Dual-Chamber Syringe kits with a 10 cc or larger luer lock syringe. For further information, please contact your healthcare provider or call the Medical Information Department at Wyeth Pharmaceuticals, 1-800-934-5556.

Note: Luer-to-luer syringe connectors are not provided in the kits. Contact your XYNTHA supplier to order.

1. Reconstitute all XYNTHA Prefilled Dual-Chamber Syringes according to instructions described in **PREPARATION AND RECONSTITUTION** section. Holding the XYNTHA Prefilled Dual-Chamber Syringe in an upright position, slowly advance the plunger rod until most, but not all, of the air is removed from the drug product chamber.

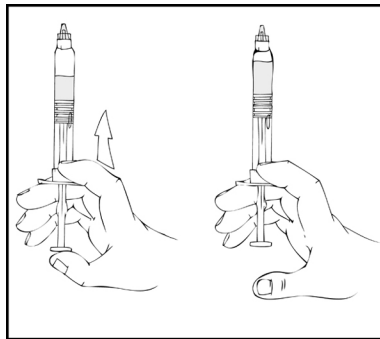

2. Remove the luer-to-luer syringe connector from its package.
3. After removing the protective blue vented cap, connect a sterile 10 cc or larger luer lock syringe to one opening (port) in the syringe connector and the XYNTHA Prefilled Dual-Chamber Syringe to the remaining open port on the opposite end.

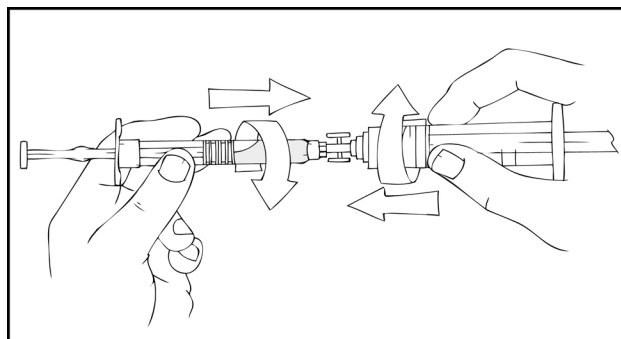

4. With the XYNTHA Prefilled Dual-Chamber Syringe on top, slowly depress the plunger rod until the contents empty into the 10 cc or larger luer lock syringe.

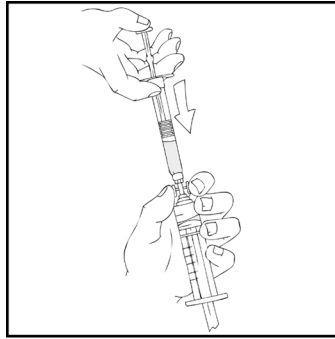

5. Remove the empty XYNTHA Prefilled Dual-Chamber Syringe and repeat procedures 3 and 4 **above** for any additional reconstituted syringes.
6. Remove the luer-to-luer syringe connector from the 10 cc or larger luer lock syringe and attach the infusion set as directed [*see* **INFUSION** section].

Note: Dispose of all unused solution, the empty XYNTHA Prefilled Dual-Chamber Syringes, and other used medical supplies in an appropriate container for throwing away medical waste that might hurt others if not handled properly.

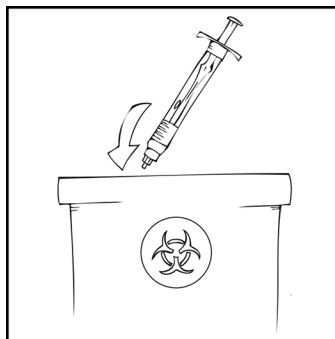

This Patient Package Insert has been approved by the U.S. Food and Drug Administration.



This product's label may have been updated. For current package insert and further product information, please visit www.wyeth.com or call our medical communications department toll-free at 1-800-934-5556.



Wyeth[®]

Wyeth Pharmaceuticals Inc.
Philadelphia, PA 19101

W10547C001

ET01

Rev 08/10